

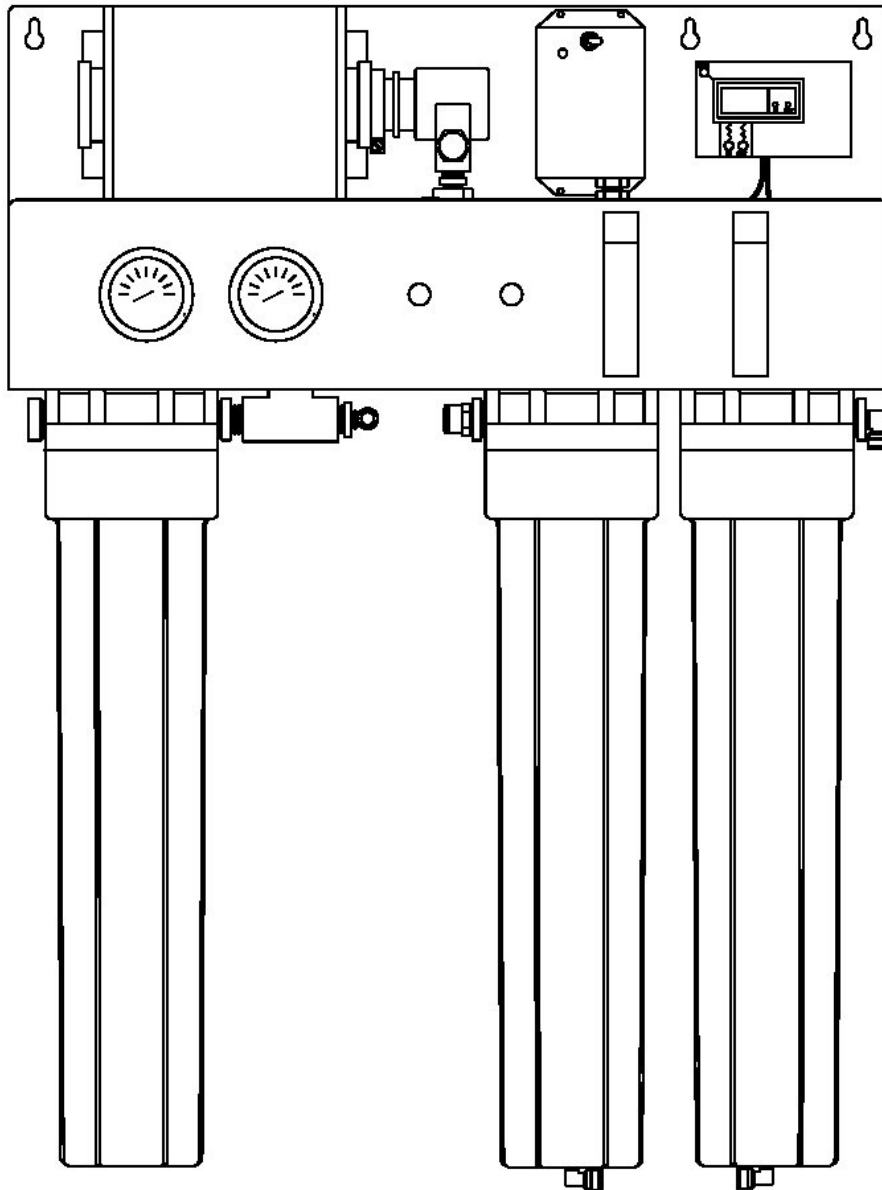

REVERSE OSMOSIS

INSTALLATION AND OPERATION MANUAL

Model R13



IMPORTANT

Please read the entire manual before proceeding with the installation and startup:

- Do not use where the water is microbiologically unsafe.
- Always turn off the unit, shut off the feed water, and disconnect the electrical power when working on the unit.
- Never allow the pump to run dry.
- Never start the pump with the reject valve closed.
- Never allow the unit to freeze or operate with a feed water temperature above 100°F.

NOTES

Changes in operating variables are beyond the control of Alamo Water Refiners. The end user is responsible for the safe operation of this equipment. The suitability of the product water for any specific application is the responsibility of the end user.

Successful long-term performance of an RO system depends on proper operation and maintenance of the system. This includes the initial system startup and operational startups and shutdowns. Prevention of fouling or scaling of the membranes is not only a matter of system design, but also a matter of proper operation. Record keeping and data normalization are required in order to know the actual system performance and to enable corrective measures when necessary. Complete and accurate records are also required in case of a system performance warranty claim.

Changes in the operating parameters of an RO system can be caused by changes in the feed water or can be a sign of trouble. Maintaining an operation and maintenance log is crucial in diagnosing and preventing system problems. For your reference, a typical log sheet is included in this manual.

TABLE OF CONTENTS

I. Introduction

- A. Specifications
- B. RO Overview
- C. Pre-treatment

II. Controls, Indicators, and Components

III. Operation

- A. Installation
- B. Plumbing Connections
- C. Electrical
- D. Startup
- E. Control Function
- F. Operation and Maintenance Log
- G. Troubleshooting

IV. Replacement Parts List

V. Membrane Replacement

VI. Appendix

- Temperature Correction Factors

I. INTRODUCTION

The separation of dissolved solids and water using RO membranes is a pressure driven temperature dependent process. The membrane material is designed to be as permeable to water as possible, while maintaining the ability to reject dissolved solids.

The main system design parameters require the following:

- Internal flows across the membrane surface must be high enough to prevent settling of fine suspended solids on the membrane surface.
- The concentration of each dissolved ionic species must not exceed the limits of solubility anywhere in the system.
- Pre-treatment must be sufficient to eliminate chemicals that would attack the membrane materials.

A. SPECIFICATIONS

| | R13-0250 | R13-0600 | R12-1200 |
|---|----------------------|-----------------|-----------------|
| Maximum Productivity (Gallons per day) | 250 | 600 | 1200 |
| Quality (average membrane rejection) | 98 % | 98 % | 98 % |
| Recovery (user adjustable) | 8 - 75 % | 17 – 75% | 34 - 75 % |
| Membrane Size | 3" x 10" | 3" x 20" | 3" x 20" |
| Number Of Membranes | 1 | 1 | 2 |
| Prefilter (System ships with one 5 micron cartridge) | 10" | 20" | 20" |
| Feed Water Connection | 3/4" NPTF | | |
| Product Water Connection (Tubing OD) | 3/8" | | |
| Reject Water Connection (Tubing OD) | 3/8" | | |
| Feed Water Required (Maximum) | 2.4 gpm | | |
| Feed Water Pressure (Minimum) | 10 psi | | |
| Drain Required (Maximum) | 2.4 gpm | | |
| Electrical Requirement | 120 VAC 60 Hz 8 amps | | |
| Motor Horse Power | 1/2 | | |
| Dimensions W x H x D (approximate) | 26" x 26" x 9" | 26" x 36" x 9" | |
| Shipping Weight (Estimated Pounds) | 50 | 60 | 75 |

Notes:

- Maximum production based on a feed water of 77°F, SDI < 3, 1000 ppm TDS, and pH 8. Individual membrane productivity may vary (± 15%). May be operated on other feed waters with reduced capacity.
- Percent Rejection is based on membrane manufactures specifications; overall system percent rejection may be less.

B. RO OVERVIEW

Reverse osmosis systems utilize semipermeable membrane elements to separate the feed water into two streams. The pressurized feed water is separated into purified (product) water and concentrate (reject) water. The impurities contained in the feed water are carried to drain by the reject water. It is critical to maintain adequate reject flow in order to prevent membrane scaling and/or fouling.

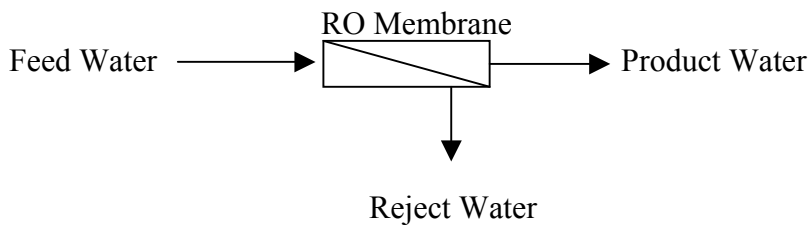

C. PRETREATMENT

The RO feed water must be pretreated in order to prevent membrane damage and/or fouling. Proper pretreatment is essential for reliable operation of any RO system.

Pretreatment requirements vary depending on the nature of the feed water. Pretreatment equipment is sold separately. The most common forms of pretreatment are described below.

Media Filter - Used to remove large suspended solids (sediment) from the feed water. Backwashing the media removes the trapped particles. Backwash can be initiated by time or differential pressure.

Water Softener - Used to remove calcium and magnesium from the feed water in order to prevent hardness scaling. The potential for hardness scaling is predicted by the Langelier Saturation Index (LSI). The LSI should be zero or negative throughout the unit unless approved anti-scalants are used. Softening is the preferred method of controlling hardness scale.

Carbon Filter - Used to remove chlorine and organics from the feed water. Free chlorine will cause rapid irreversible damage to the membranes.

The residual free chlorine present in most municipal water supplies will damage the thin film composite structure of the membranes used in this unit. Carbon filtration or sodium bisulfite injection should be used to completely remove the free chlorine residual.

Chemical Injection - Typically used to feed antiscalant, coagulant, or bisulfite into the feed water or to adjust the feed water pH.

Prefilter Cartridge - Used to remove smaller suspended solids and trap any particles that may be generated by the other pretreatment. The cartridge(s) should be replaced when the pressure drop across the housing increases 5 - 10 psig over the clean cartridge pressure drop.

The effect of suspended solids is measured by the silt density index (SDI) test. An SDI of five (5) or less is specified by most membrane manufacturers and three (3) or less is recommended.

Iron & Manganese - These foulants should be removed to less than 0.1 ppm. Special media filters and/or chemical treatment is commonly used.

pH - The pH is often lowered to reduce the scaling potential. If the feed water has zero hardness, the pH can be raised to eliminate CO₂.

Silica: Reported on the analysis as SiO₂. Silica forms a coating on membrane surfaces when the concentration exceeds its solubility. Additionally, the solubility is highly pH and temperature dependent. Silica fouling can be prevented with chemical injection and/or reduction in recovery.

II. CONTROLS, INDICATORS, and COMPONENTS (see figure 1)

- A. On / Off Switch – Turns the unit on and off.
- B. Low-pressure indicator – Turns on when low pump inlet pressure is detected.
- C. Reject Control Valve - Controls the amount of reject flow.
- D. Reject Recycle Control Valve – Controls the amount of recycle flow.
- E. Prefilter Outlet Pressure Gauge - Indicate the outlet pressures of the prefilter.
- F. Pump Discharge Pressure Gauge - Indicates the membrane feed pressure.
- G. Reject Flow Meter - Indicates the reject flow rate in gallons per hour (gph).
- H. Product Flow Meter - Indicates the product flow rate in gallons per hour (gph).
- I. Prefilter Housing - Contains the RO prefilter.
- J. RO Feed Pump - Pressurizes the RO feed water.
- K. RO Membrane Housing(s) - Contains the RO membrane(s).
- L. Water Quality Meter – Indicates the quality of the feed and product water in parts per million of total dissolved solids (PPM – TDS).
- M. Feed Water Inlet.

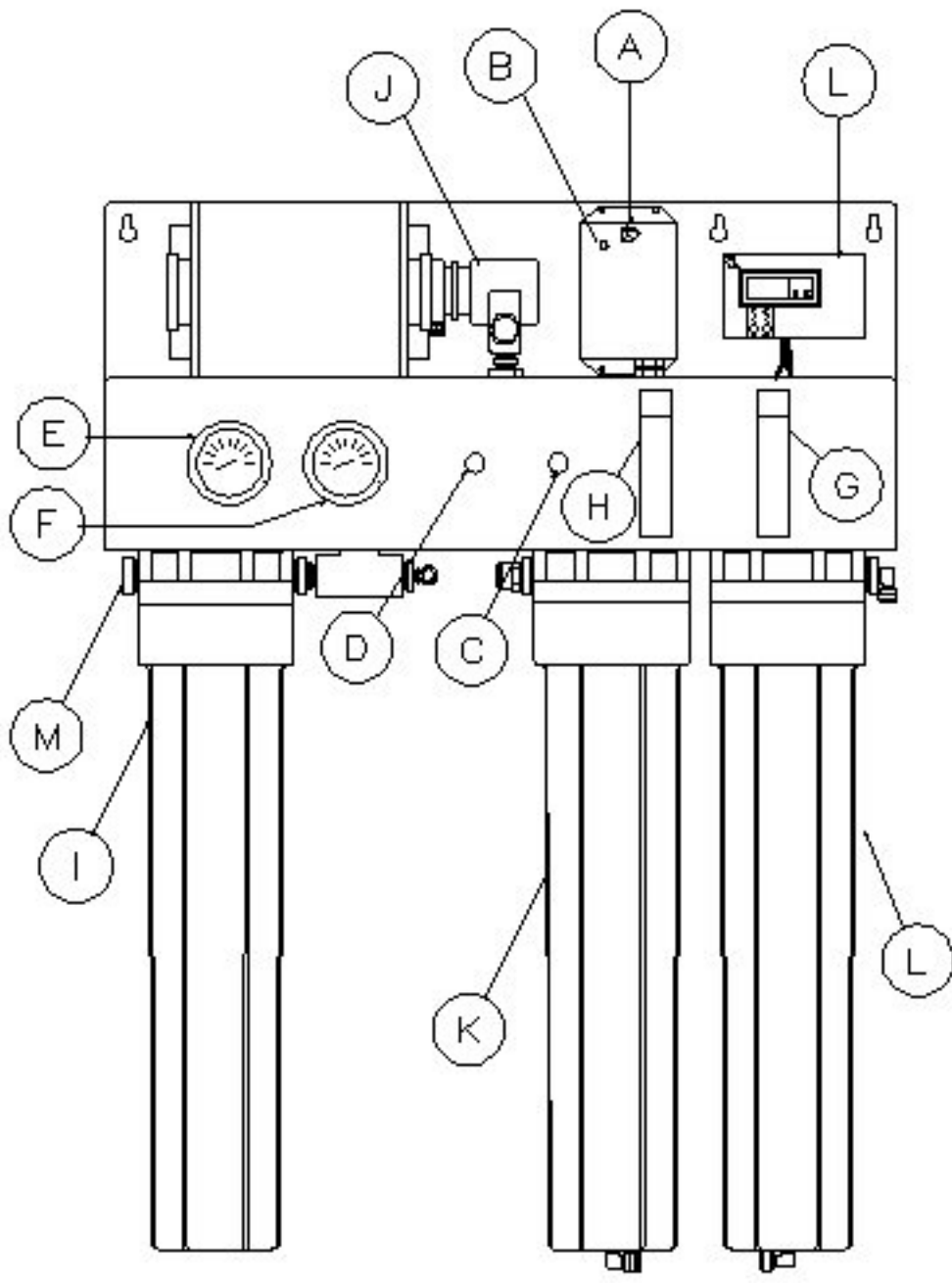

Figure 1

III. OPERATION

A. INSTALLATION

1. Proper pretreatment must be determined and installed prior to the RO system.
2. The water supply and pretreatment equipment should be sufficient to provide a minimum of 10-psig at the maximum feed flow.
3. An electrical receptacle with a ground fault interrupt (GFI) is highly recommended.
4. Responsibility for meeting local electrical and plumbing codes lies with the owner / operator.
5. Install indoors in an area protected from freezing. Space allowances for the removal of the membranes from the pressure vessels should be provided.
6. The prefilter housing and membrane housings are usually removed for shipment. The RO membrane housing(s) can be identified by the fitting installed in the bottom. The prefilter housing does not have a fitting in the bottom.
7. Install the prefilter housing with its cartridge (see figure #1, item I).
8. Install the RO membrane housing(s) with the membrane(s) (see figure #1, item K).
9. Connect the tubing to the bottom of the RO membrane housing(s). On system with one membrane the tubing connects from the bottom of the membrane housing to the reject valve assembly. On system with two membranes, one piece of tubing connects from the bottom of the left membrane to the inlet (upper right) of the right membrane. A second piece of tubing connects the bottom of the right membrane to the reject valve assembly. The fittings are tagged to indicate the proper tubing connections.

B. PLUMBING CONNECTIONS

Note: It is the responsibility of the end user to ensure that the installation is done according to local codes and regulations.

1. Connect the pretreated feed water line to the prefilter inlet (Figure # 1 item M). A feed water shutoff valve should be located within 10 feet of the system.
2. Temporarily connect the product water outlet to a drain. The product outlet is located behind the panel at the top of the product flow meter. The product water line should never be restricted. Membrane and/or system damage may occur if the product line is blocked.
3. Connect the reject water outlet to a drain. The reject outlet is located behind the panel at the top of the reject flow meter. The reject drain line should never be restricted. Membrane and/or system damage may occur if the reject drain line is blocked. An air gap must be located between the end of the drain line and the drain. The use of a standpipe or other open drain satisfies most state and local codes and allows for visual inspection and sampling.

C. ELECTRICAL

Note: It is the responsibility of the end user to ensure that the installation is done according to local codes and regulations.

1. Make sure the on / off switch is in the off position (Figure # 1 item A).
2. Plug the unit into a standard 120 volt 3 prong outlet. An outlet protected with a ground fault interrupt (GFI) is recommended.

D. STARTUP

1. Verify that the pretreatment equipment is installed and working properly. Verify that no free chlorine is present in the feed water.
2. Verify that the on / off switch is in the off position.
3. Verify that a filter cartridge is installed in the prefilter housing.
4. Open the reject control valve completely (Figure # 1 item C) by turning it counterclockwise.
5. Close the reject recycle control valve (Figure # 1 item D) completely by turning it clockwise.
6. Open the feed water shutoff valve installed in step III-B-1 above.
7. Move the controller on/off switch to the on position.
8. Allow the unit to run for 15 – 30 minutes to flush the preservative from the membrane(s).
9. Adjust the reject control valves (Figure # 1 items C & D) until the desired flows are achieved. Closing the reject valve increases the product flow and decreases the reject flow. Opening the reject recycle valve decreases both the reject and product flow. See the flow rate guidelines and temperature correction table in the appendix to determine the flow rates for different operating temperatures.
10. Allow the product water to flow to drain for 30 minutes.
11. Turn off the system and connect the product line to the point of use. The product water line should never be restricted. Membrane and/or system damage may occur if the product line is blocked.
12. Restart the system and record the initial operating data using the log sheet.

E. CONTROL FUNCTION

1. When the on / off switch is in the on position, the inlet valve opens and the pump runs. If the water pressure feeding the pump drops below 10 psi for more than 5 seconds, the pump will turn off and the amber light on the control box will turn on. The controller will automatically reset after 30 minutes and the pump will turn back on. Cycle the on / off switch to manually reset a low pressure shutdown.
2. Quality Meter – The quality meter measures the feed water and product water total dissolved solids (TDS) in parts per million (PPM). The lower the TDS the more pure the water is. To check the TDS press the power button, then press either the IN or OUT button. The IN button checks the feed water TDS and the OUT button checks the product water TDS. The meter will automatically turn itself off after a few seconds.

The quality meter is powered by two AAA batteries. To replace the batteries, lift the meter out of the bracket and remove the back cover.

F. Operation and Maintenance Log

| DATE | PRODUCT GPM | REJECT GPM | PUMP DISCHARGE PRESSURE | FEED TDS PPM | PRODUCT TDS PPM | FEED WATER TEMP | FEED WATER HARDNESS | FEED WATER CHLORINE LEVEL | PRE FILTER INLET PRESSURE | PRE FILTER OUTLET PRESSURE | REMARKS |
|------|-------------|------------|-------------------------|--------------|-----------------|-----------------|---------------------|---------------------------|---------------------------|----------------------------|---------|
| | | | | | | | | | | | |
| | | | | | | | | | | | |
| | | | | | | | | | | | |
| | | | | | | | | | | | |
| | | | | | | | | | | | |
| | | | | | | | | | | | |
| | | | | | | | | | | | |
| | | | | | | | | | | | |
| | | | | | | | | | | | |
| | | | | | | | | | | | |
| | | | | | | | | | | | |
| | | | | | | | | | | | |
| | | | | | | | | | | | |
| | | | | | | | | | | | |
| | | | | | | | | | | | |
| | | | | | | | | | | | |
| | | | | | | | | | | | |
| | | | | | | | | | | | |
| | | | | | | | | | | | |
| | | | | | | | | | | | |
| | | | | | | | | | | | |
| | | | | | | | | | | | |
| | | | | | | | | | | | |
| | | | | | | | | | | | |
| | | | | | | | | | | | |
| | | | | | | | | | | | |

Note: Change the prefilter when the differential pressure increases by 5 - 10 psi over the clean differential pressure.
 Clean the RO membrane(s) when the product flow drops by 15% or more. (See appendix)

G. TROUBLESHOOTING

| RO MEMBRANE TROUBLE SHOOTING GUIDE | | | | | | |
|------------------------------------|---------------------|-----------------------------|--------------------------------|---|--|--|
| SYMPTOMS | | | Location | Possible Causes | Verification | Corrective Action |
| Salt Passage | Permeate Flow | Pressure Drop | | | | |
| Normal to increased | Decreased | Normal to increased | Predominantly first stage | Metal oxide | Analysis of metal ions in cleaning solution. | Improved pretreatment to remove metals. Cleaning with acid cleaners. |
| Normal to increased | Decreased | Normal to increased | Predominantly first stage | Colloidal fouling | SDI measurement of feed/ X-ray diffraction analysis of cleaning sol. residue. | Optimize pretreatment system for colloid removal. Clean with high pH, anionic detergent formulation. |
| Increased | Decreased | Increased | Predominantly last stage | Scaling (CaSO ₄ , CaSO ₃ , BaSO ₄ , SiO ₂) | Analysis of metal ions in cleaning sol. Check LSI of reject. Calculate maximum solubility for CaSO ₄ , BaSO ₄ , SiO ₂ in reject analysis. | Increase acid addition and scale inhibitor for CaSO ₃ and CaSO ₄ . Reduce recovery. Clean with an acid formulation for CaCO ₃ , CaSO ₄ and BaSO ₄ . |
| Normal to moderate increase | Decreased | Normal to moderate increase | Can occur in any stage | Biological fouling | Bacteria count in permeate and reject. Slime in pipes and vessels. | Shock dosage of sodium bisulfite. Continuous feed of low conc. bisulfite at reduced pH. Peracetic acid sterilization. Clean with alkaline anionic surfactant. Chlorine dosage upstream with dechlorination. Replace cartridge filters. |
| Decreased or moderately increased | Decreased | Normal | All stages | Organic fouling | Destructive testing, e.g. IR reflection analysis. | Optimization of pretreatment system (e.g. coagulation process.) Resin/activated carbon treatment. Clean with high pH detergent. |
| Increased | Increased | Decreased | Most severe in the first stage | Chlorine oxidant attack | Chlorine analysis of feed. Destructive element test. | Check chlorine feed equipment and dechlorination equipment. |
| Increased | Increased | Decreased | Most severe in the first stage | Abrasion of membrane by crystalline material | Microscopic solids analysis of feed. Destructive element test. | Improved pretreatment. Check all filters for media leakage. |
| Increased | Normal to increased | Decreased | At random | O-ring leaks, End or side seal glue leaks. | Probe test. Vacuum test. Colloidal material passage. | Replace O-rings. Repair or replace elements. |
| Increased | Normal to low | Decreased | All stages | Conversion too high. | Check flows and pressures against design guidelines | Reduce conversion rate. Calibrate sensors. Increase analysis and data collection. |

RO SYSTEM TROUBLE SHOOTING

| PROBLEM | REMEDY |
|---|--|
| General | |
| High Product Water TDS | |
| Membrane frozen, high temp, or backpressure. | Replace membrane. |
| Membrane attack by chlorine | Carbon pre-filter may be exhausted. Replace filter and membrane. |
| Product seal on end cap. | Determine if seal or o-ring is bad. Replace as needed. |
| No Product Water or Not Enough Product Water | |
| Feed water shut off. | Turn on feed water. |
| Low feed pressure. Feed pressure must be at least 10 psi. | Consider booster pump. |
| Pre-filter cartridge clogged. | Replace pre-filter cartridge. |
| Membrane fouled. | Determine and correct cause; replace or clean membrane. |
| Product check valve stuck. | Clean or replace check valve. |
| Low pump discharge pressure | Adjust reject valve or replace pump |
| Low feed water temperature | Increase membrane feed pressure or heat the feed water. |

IV. REPLACEMENT PARTS LIST

A list of common replacement parts is provided below. Contact your dealer for replacement parts assistance.

| Part Number | Description |
|--------------|--|
| FPMB5-978 | Prefilter for R13-0250 |
| FPMB5-20 | Prefilter for R13-0600 & R13-1200 |
| R96310 | RO membrane for R13-0250 |
| R96320 | RO membrane for R13-0600 & R13-1200 |
| PG07B25 | Prefilter pressure gauge 0 – 100 psi |
| PG20B25 | Pump discharge pressure gauge 0 – 300 psi |
| R5645 | Product and reject flow meter 0 – 50 gph |
| WDM-2 | Water quality meter |
| R2200-120/60 | Motor 0.5 HP single phase 120 volt |
| R2101-140 | Pump 140 GPH carbonator with relief valve |
| R23-1070S | Low pressure controller with on/off switch |
| R23-PS32 | Low pressure switch, ¼” MPT |
| NV-10 | Reject & recycle needle valve |
| R2402 | Inlet solenoid valve, 1/2”, 120 volt coil |
| R9812-4SS | Product check valve |

V. MEMBRANE REPLACEMENT

1. Turn off the system and close the feed water shutoff valve.
2. Disconnect the tubing from the bottom of the membrane housing(s).
3. Unscrew the membrane housing(s) and remove the membrane(s). Please note how the membranes were installed in the housing(s). The new membranes need to be installed in the same orientation.
4. Install the new membrane(s) in the housing(s) and screw the housing(s) back on to the system. The membranes should be installed with the with the brine seals at the top of the housing.
5. Reconnect the tubing to the bottom of the membrane housing(s).
6. Follow the start up procedure in section III-D.

VI. APPENDIX

The following tables are intended as a guide to determining the flow rates for the R13 series RO systems. All flows are in gallons per hour (GPH).

Nominal flows for systems operating at 50% recovery.

| | R12-0250 | R12-0600 | R12-1200 |
|--------------------|-----------------|-----------------|-----------------|
| Product GPH | 10.4 | 25 | 50 |
| Reject GPH | 10.4 | 25 | 50 |

Temperature Correction Factors

| Deg C | Deg F | Correction Factor |
|--------------|--------------|--------------------------|
| 25 | 77 | 1.00 |
| 24 | 75.2 | 0.97 |
| 23 | 73.4 | 0.94 |
| 22 | 71.6 | 0.92 |
| 21 | 69.8 | 0.89 |
| 20 | 68 | 0.86 |
| 19 | 66.2 | 0.84 |
| 18 | 64.4 | 0.81 |
| 17 | 62.6 | 0.79 |
| 16 | 60.8 | 0.77 |
| 15 | 59 | 0.74 |
| 14 | 57.2 | 0.72 |
| 13 | 55.4 | 0.70 |
| 12 | 53.6 | 0.68 |
| 11 | 51.8 | 0.66 |
| 10 | 50 | 0.64 |
| 9 | 48.2 | 0.62 |
| 8 | 46.4 | 0.61 |
| 7 | 44.6 | 0.59 |
| 6 | 42.8 | 0.57 |
| 5 | 41 | 0.55 |

Multiply the nominal product flow at 25° C by the temperature correction factor to determine the flow at various other temperatures.