

Series W-Z45H-25Q

Gate Valve, NRS, Metal Seated

Size: DN50-DN300

Implementation of piping system on and off; Used in plumbing, HVAC, irrigation, commercial, and industrial application.

Features

- Low pressure drop
- Large temperature range
- Bidirectional flow
- Sealed performance
- Compact design
- High reliability and long durability

Pressure-Temperature

- Nominal Pressure: PN25
- Temperature Range: -10°C~120°C

Test Pressures

Hydraulic

Shell: 37.5 bar

Seat: 27.5 bar

Material

Component	Material	EN Spec	ASTM Spec
Body	Ductile Iron	DN-JS1050	A536 65-45-12
Bonnet	Ductile Iron	DN-JS1050	A536 65-45-12
Seat	Bronze	EN1982 CC491K	B62 C83600
Wedge	Ductile Iron	DN-JS1050	A536 65-45-12
Wedge Trim	Bronze	EN1982 CC491K	B62 C83600
Stem	Stainless Steel	BS970 420S37	AISI 420
Wedge Nut	Brass	CuZn39Pb3	B16 C36000
Gasket	PTFE	Polytetrafluoroethylene	ASTM D3294
Packing	EPDM	EN681-1	ASTM D3568
Packing Nut	Stainless Steel	BS970 304S15	AISI 304
Bonnet Bolts & Nuts	Stainless Steel	BS970 304S15	AISI 304
Hand Wheel	Ductile Iron	EN-JS1050	A536 65-45-12

Specification

- Connection Standard: PN25 to EN1092-2
- Corrosion Protection: internally and externally liquid epoxy painted
- Medium: water, oil, gas

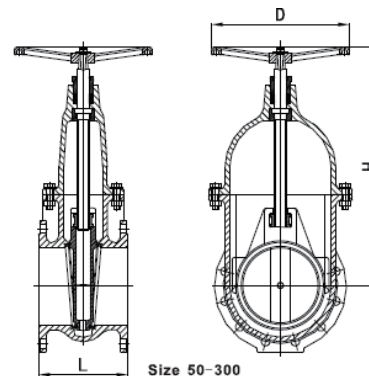

Installation Dimensions

Size(mm)	50(mm)	65(mm)	80(mm)	100(mm)	125(mm)	150(mm)	200(mm)	250(mm)	300(mm)
L	178	190	203	229	254	267	292	330	356
H	214	223	262	323	380	438	518	615	705
D	200	200	254	254	315	315	315	405	405

Pressure-Temperature Chart

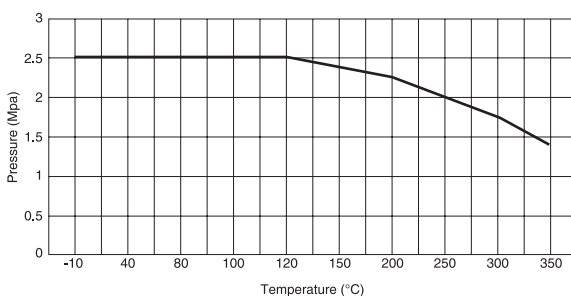

Characteristic Curve

