



RD-100-CP-15

Tag: _____

Large Area IRMA Roof Drain with 15"x15" Promenade Top

Components:

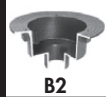

SPECIFICATION: Watts Drainage Products RD-100-CP-15 epoxy coated cast iron roof drain with deep sump and wide serrated flashing flange, membrane clamp, square adjustable lacquered cast iron collar with 15-5/8"(397) square epoxy coated ductile iron (standard) grate with 3/8"(10) maximum width drainage slots.

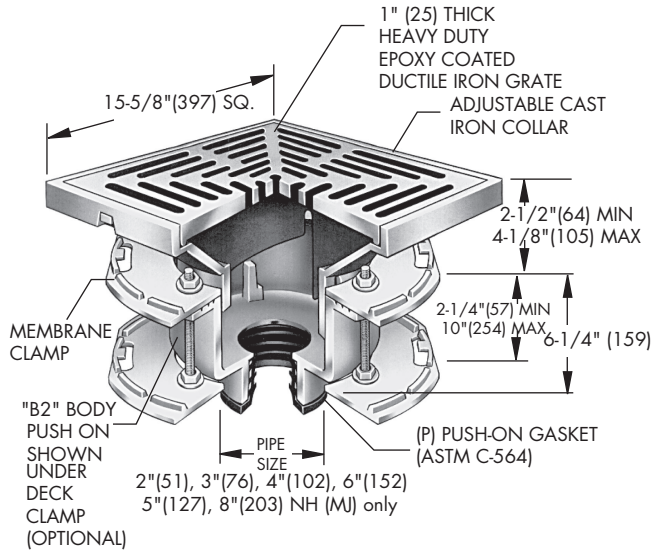

Load Rating & Free Area

Suffix	Load Rating	Free Area Sq. In.
CP-15-1	*XHD	57
CP-15-3	*XHD	57
CP-15-4	*XHD	57

Deck opening 10" (254) with sump receiver 13-1/4" (337)

NOTICE

The load classifications are in accordance with the American National Standards ASME A112.21.1M ASME Ratings are as follows:
XHD - Safe Live Load 7500-10000 lbs.(3375-4500kg)
The above categories are given as a guide only.
Please consult factory.

**Side Outlet (-SO) option only available in 2"(51), 3"(76), 4"(102) pipe sizes.
Underdeck Clamp (-BED and -D options) are not available when -SO is selected.

Grate (Select One)	
Suffix	Description
-1	Nickel Bronze <input type="checkbox"/>
-3	Stainless Steel <input type="checkbox"/>
-4	Ductile Iron <input type="checkbox"/>

Order Code: RD-10 - CP -15 - -

Ex. RD-102P-CP-15-1

Pipe Sizing (Select One)	
Suffix	Description
2	2"(51) Pipe Size <input type="checkbox"/>
3	3"(76) Pipe Size <input type="checkbox"/>
4	4"(102) Pipe Size <input type="checkbox"/>
5	5"(127) Pipe Size <input type="checkbox"/>
6	6"(152) Pipe Size <input type="checkbox"/>
8	8"(203) Pipe Size <input type="checkbox"/>

Outlet Type (Select One)	
Suffix	Description
NH	No Hub (MJ) <input type="checkbox"/>
P	Push On <input type="checkbox"/>
T	Threaded Outlet <input type="checkbox"/>
X	Inside Caulk <input type="checkbox"/>

Options (Select One or More)	
Suffix	Description
-A	Accutrol weir (specify # 1-6 slots) <input type="checkbox"/>
-B	Sump Receiver Flange <input type="checkbox"/>
-BED	Sump Receiver, Adj Ext., Deck Clamp <input type="checkbox"/>
-C	Secondary Membrane Clamp <input type="checkbox"/>
-D	Underdeck Clamp <input type="checkbox"/>
-E	Adjustable Extension <input type="checkbox"/>
-GSS	Stainless Steel Ballast Guard <input type="checkbox"/>
-H	Adj. to 6" IRMA Ballast Guard <input type="checkbox"/>
-R	2" High External Water Dam <input type="checkbox"/>
-SO	Side Outlet** <input type="checkbox"/>
-V	Fixed Extension(1-1/2",2",3",4") <input type="checkbox"/>
-W	Adj. Water Level Regulator <input type="checkbox"/>
-W-1	Waterproofing Flange <input type="checkbox"/>
-Z	Extended Integral Wide Flange <input type="checkbox"/>
-5	Sediment Bucket <input type="checkbox"/>
-6	Vandal Proof Top <input type="checkbox"/>
-9	Hinged Grate <input type="checkbox"/>
-10	Secured Top <input type="checkbox"/>
-12	Galvanized Top <input type="checkbox"/>
-13	All Galvanized <input type="checkbox"/>
-113M	Special Epoxy from 3M Range <input type="checkbox"/>

Optional Body Material (NH Only)	
Suffix	Description
-60	PVC Body w/Socket Outlet <input type="checkbox"/>
-61	ABS Body w/Socket Outlet <input type="checkbox"/>

Job Name _____

Contractor _____

Job Location _____

Contractor's P.O. No. _____

Engineer _____

Representative _____

Watts product specifications in U.S. customary units and metric are approximate and are provided for reference only. For precise measurements, please contact Watts Technical Service. Watts reserves the right to change or modify product design, construction, specifications, or materials without prior notice and without incurring any obligation to make such changes and modifications on Watts products previously or subsequently sold.



A Watts Water Technologies Company

USA: Tel: (800) 338-2581 • Fax: (828) 248-3929 • Watts.com

Canada: Tel: (905) 332-4090 • Fax: (905) 332-7068 • Watts.ca

Latin America: Tel: (52) 81-1001-8600 • Fax: (52) 81-8000-7091 • Watts.com

ES-WD-RD-100-CP-15-CAN 1506

© 2015 Watts